

ACS-008K

Antenna Control System, VHF/UHF TX/RX coupler/switch, 30-512 MHz
Naval Antennas and Systems: Submarine



Description

This 8-Way VHF Switch is designed for use in systems where LVHF/VHF/UHF transceivers share common TX and RX antennas. The unit includes:

- Two independent 4-way switches for automatic TR switching and combining of 4 transceivers sharing common antennas.
- Configurable switch matrix used to select one out of 6 TX antennas for each of the 4-way switches.
- Three diplexers channels, where of two provides forward and reverse power monitoring.
- Diplexer channel switch matrix.
- Control system with CPU, Graphical display and interfaces (LAN, USB).
- 24 V power supply.
- 100 W power handling for the 8 Tx ports, and lower diplexer channels (under 700 MHz), and 20W CW (500 W peak) for the high diplexer channels (over 700 MHz).

The main function of the ACS0008-K V/UHF-switch is two, 4-way automatic switches (each equivalent to the Comrod product ACS004). It consist of automatic TR switches, 4:1 combiner, LNA and SP6T switches. Each switch supports 4 transceivers operating in the frequency band 30 to 512 MHz, and a dedicated fail-safe signal path.

The RX signal may be selected from either of the two RX antenna connectors. If none of them are used, the signal is routed from the TX antenna which is then used for both TX and RX. The RX signal is distributed to all the transceivers TRX1 .. 4(5 .. 8) through an RF-filter, an LNA, a power splitter and the automatic TR switches. Four additional RX ports are available (RX1 .. RX4). These can be used if dedicated Rx and Tx antennas are desired.

A transceiver in TX mode is detected by the automatic TR switch that issues signals (PTT) to the control logic to enable a direct signal path to the selected TX antenna through the SP6T switch. If more than one transceiver is in TX mode, the control logic will make the SP6T connect the antenna to the 4:1 combiner and issue signals (Aux) to the automatic TR switch to connect to the 4-way combiners by using its auxiliary TX output. The phase of the signals are maintained in any combination. If a single transceiver is in Tx mode, the signal will bypass the 4:1 combiner and go straight to the switch matrix and antenna port, introducing less than 3dB loss through the whole switch.

Transceivers may be configured for priority in TX mode, causing its signal to by-pass the 4-way combiner while the other transceivers sharing the same 4-way combiner are connected to the 50ohm dummy-load located inside the 4-way combiner. Since signals with priority (like GMDSS) always bypass the 4:1 combiner due to implemented logic, inhibit output signals are not needed in order to ensure priority. Inhibit signals can be implemented o the end user requirement.



ACS008K

The unit occupies 6 units of 450 mm depth in a 19" rack

Control System

The control system includes the switch control logic and a CPU with display and interfaces (LAN, USB). The switch control logic supports the mission-critical functions without need of any CPU interaction. The CPU provides both local and remote user interface for configuration and monitoring of the unit.

Power Supply

The power supply provides the required internal voltages as well as the galvanic isolation of the external 24 V power source.

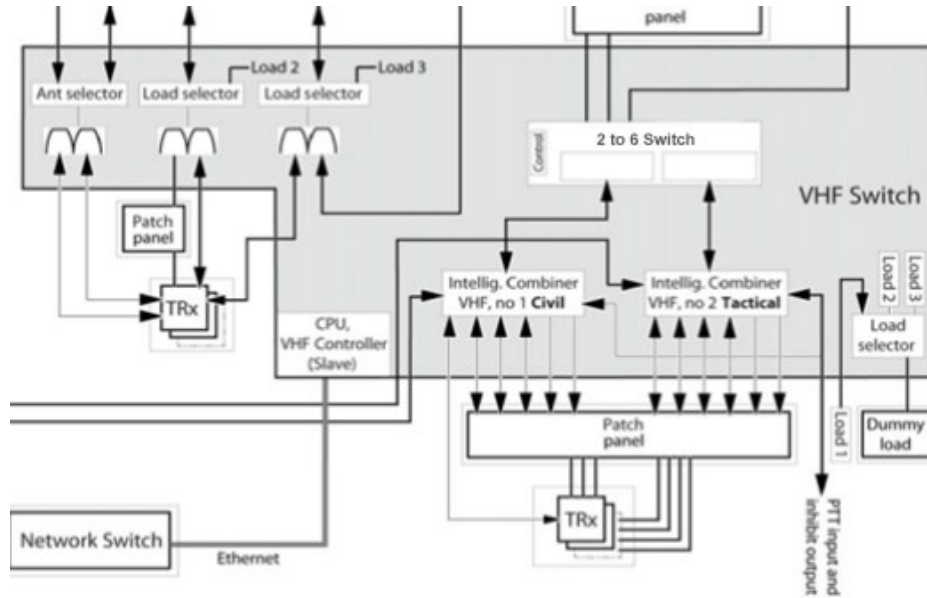

ACS008-K Block Diagram

Technical Specifications

- 4-way switch: Frequency range : 30-512 MHz
- TX signal path: TX level : 17dBm .. 50 dBm 50 mW .. 100 W
Insertion loss : Direct < 3 dB, Combined < 10 dB
Phase integrity : < 20 deg Phase shift direct to combined
Switching speed : 15 us (typical) : 10ms (typical) Applies to electro-mechanical relays
- RX signal path: Gain : 1.5 dB +/- 2 dB
P-1dB input : 10 dBm typical
IP3 input : 22 dBm typical
Noise figure : 5 dB typical
Output isolation : > 20 dB Between RX-ports
Maximum input power : 30 dBm continuous
TX isolation : > 45 dB TX- to RX-ports
- Thermal properties (each 4-wayswitch):
Max RF dissipation : 150 W Applies to 4x50 W input,50 W output
Max heat sink temp : 100°C
- 2 to 6 switch: Switching time : 5 ms typical
Insertion loss : < 1 dB
- Connectors: 24 VDC : Amphenol 62GB-5016-102P
RX ant and TX ant : 50 Ω N, female

September 2018

All specifications are subject to change without notice
The information contained herein is for reference only and does not constitute a warranty of performance

Partnered Supplier



sales@eylex.com.au
www.eylex.com.au

