

AV7M

VHF, 2 dBi, one piece whip, dipole, end feed, mast mount, 1.25 m, 145–165 MHz

Commercial and Marine Antennas



Application

AV7M is a high quality dipole antenna designed for the marine VHF radio telephone service. It is a high quality antenna with a durable construction and a beautiful finish for installation on all kinds of vessels.

Electrical Specifications

Frequency Range	156–162 MHz, VSWR < 1.5:1 145–165 MHz, VSWR < 2:1
Nominal Impedance	50 Ω
Power Rating	100 W
Gain	2 dBi
Pattern	Horizontal plane: Omnidirectional Vertical plane: See reverse page
Polarisation	Vertical
Connector	UHF female standard, N-type option
DC Grounded	Yes

Mechanical Specifications

Design	Centre fed coaxial dipole. Radiating elements completely enclosed in polyurethane foam within a fibreglass tube. Mounting bracket in aluminium.
Height	1.25 m
Weight	1 kg, including U-bolts
Wind Rating	55 m/s = 201 kph
Finish	Polyurethane lacquer, white
Temperature Range	- 55°C to + 71°C
Water Proofing	IP67

Mounting

AV7M can be mounted directly onto the bulkhead by means of 4 holes in the aluminium bracket. It can also be attached to a mast or tube using the supplied M6 stainless steel U-bolts. The mounting tube can be horizontal or vertical. See page 2 for mounting details.

Suitable cable: RG8, RG213 or similar. Connector joint sealed with suitable waterproofing tape (not supplied).

Pattern and VSWR

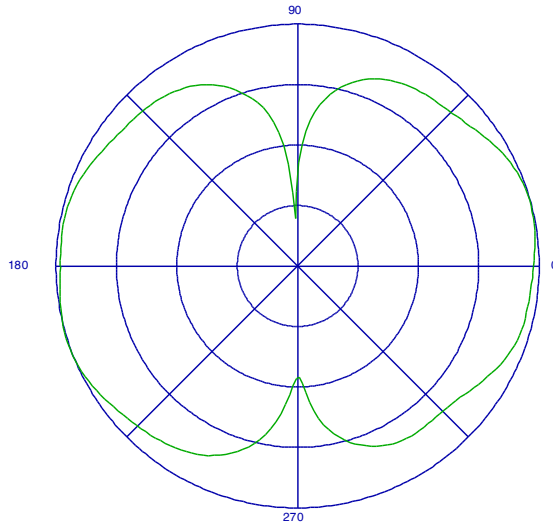

Vertical Radiation Pattern
 f=160 MHz, 40 dB dynamic range, 10 dB/div

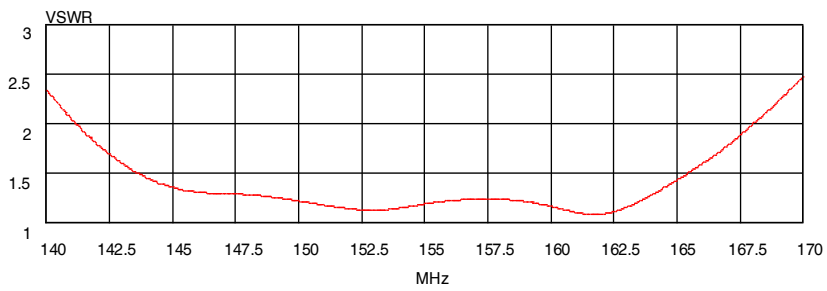

VSWR

Mounting Details

Pole Mounting

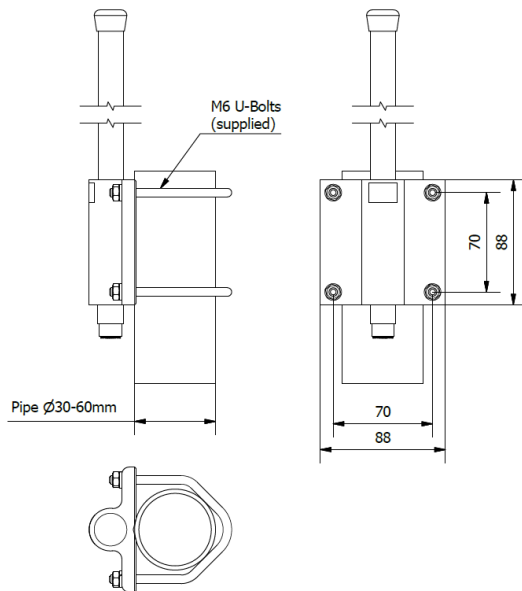

Bulkhead Mounting

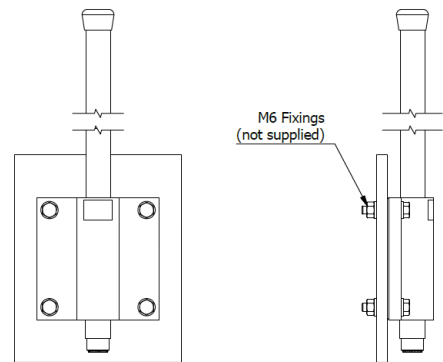

February 2021

All specifications are subject to change without notice
 The information contained herein is for reference only and does not constitute a warranty of performance

Partnered Supplier



sales@eylex.com.au
 www.eylex.com.au

