

## TM 210/3.3-1.3

3.3 m telescopic aluminium mast kit, motorised, 1.3 m retracted

### Tactical Masts: Telescopic Motorised



Comrod (formerly Wibe TM) un-guyed electric powered telescopic masts are based on a time tested and performance proven rugged design that provides performance, reliability, and safety to our users while overcoming the well known issues related to pneumatic and hydraulic masts. Masts are constructed with extruded hexagonal and circular aluminium alloy tubes, and our tracked telescopic action assisted by synthetic guides give our masts excellent tensional resistance and high rotational accuracy. Hoisting cables are protected and run in the free space between sections. All fixtures – hoisting cables, pulleys, pin and winches – are of stainless steel and hot dip galvanised steel. The unique and proven all-weather design featuring space between sections allows our masts to be raised or lowered even with an ingress of ice, sand or caked dust.

These masts are currently deployed in harsh environments that range from the deserts and snowy mountains in Iraq and Afghanistan, in humid and hot jungles in South America, to the arctic cold regions of Alaska and the Scandinavian countries. Masts are easily and quickly raised or retracted by one, two or three person teams (depending on the particular mast).

The TM 210/3.3-1.3 mast is made of extruded hexagonal aluminium alloy tubes of progressively smaller size and tracked telescopic action, with screwed on/or riveted fittings in stainless steel. The sections move inside each other on plastic guide-ways which provide the masts with excellent torsional resistance. The mast is elevated by an electric motor that is connected to a ball-screw that hoists section 2. The other sections are hoisted by steel cables. No additional staying is required. The mast is equipped with a hand crank backup.

**TM210 series masts are fully qualified to MIL-STD-810G**



Mast Type	TM 210/3.3-1.3
Elevated Height	3.3 m
Retracted Height	1.3 m
Max. Headload Area	0.35 m <sup>2</sup>
Max Vertical Headload	65 kg
Number of Sections	4
Wind Speed Operational	25 m/s
Wind Speed Survival	35 m/s
Mast Weight	70 kg
Elevation Time	20 sec
Retraction Time	20 sec
Footprint	260 x 450 mm
Base Plate Type	Non rotating
Voltage	24 VDC

\* Typical values shown. Actual values will be subject to a combination of top load weight, top load area and pointing accuracy required.

# Outline Drawing

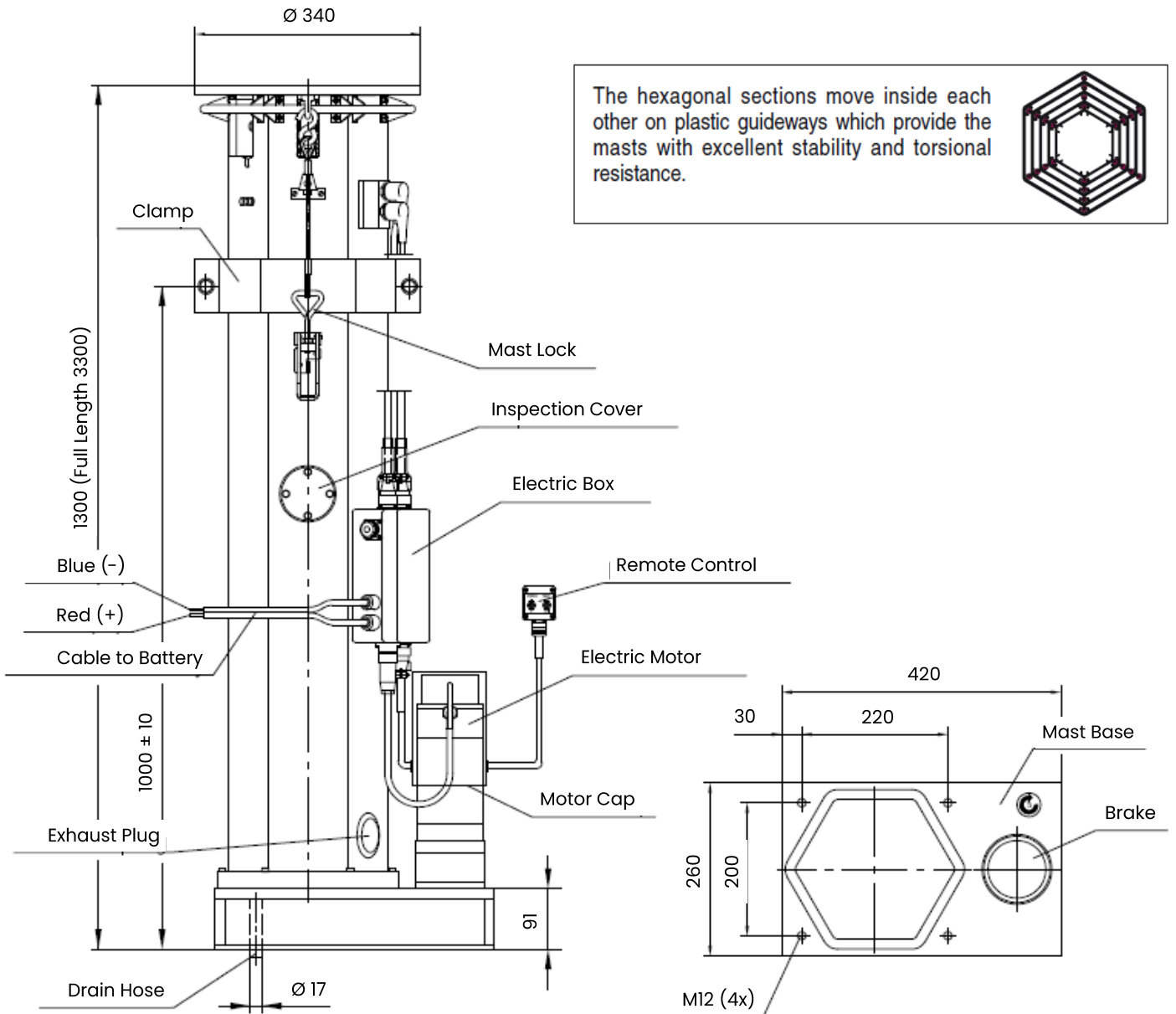

The hexagonal sections move inside each other on plastic guideways which provide the masts with excellent stability and torsional resistance.

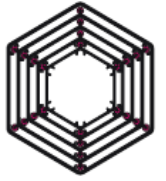

April 2020

All specifications are subject to change without notice  
 The information contained herein is for reference only and does not constitute a warranty of performance

Partnered Supplier



sales@eylex.com.au  
 www.eylex.com.au

